

MALONE[®]

~ **ROOF RACK SYSTEMS**

~ **AIRFLOW2™**

~ **50", 58" and 65"**

SILVER - MPG215, MPG216, MPG217

BLACK - MPG226, MPG227, MPG228



CHANGING THE WAY YOU GET THERE

MALONE[®]

CHANGING THE WAY YOU GET THERE

Important Note

Product Warranty & Registration Form

All information is confidential and used exclusively by MALONE only.

Dear Customer,

Thank you for your purchase of a Malone Product.

In order to be eligible for the Malone Warranty program, we ask that you contact us online at the link provided below: With-in 30 days of purchase. You can also mail this letter back to the address at the bottom.

- Online: <https://maloneautoracks.com/product-registration.php>

We will require the information below.

Here is the information collected:

First Name: _____

Last Name: _____

Address: _____

Address2: _____

City: _____

State: _____

Zip: _____

Country: _____

Email: _____

Phone: _____

Product Description/Name: _____

Product MPG# _____

Date Purchased: _____

Store Where Purchased: _____

Purchase Price: _____

Thank you for choosing Malone!

MALONE AUTO RACKS 81 County Rd. Ste 1, Westbrook, ME 04092
P: 207.774.9100 F: 207.615.0551
E: support@maloneautoracks.com W: www.maloneautoracks.com



Keys (2)

Cross Bars(2)

Inserts (2)

PARTS LIST

Installation & Loading Instructions - Please Read Before Beginning

Veillez lire les instructions avant d'entreprendre l'installation et le chargement

IMPORTANT WARNING: All vehicular transports are potentially hazardous. Any person(s) using Malone products are personally responsible for following the given directions for use and/or installation and accepts full responsibility for any and all damages or injury of any kind including death, which may result from their use and/or installation.

It is critical that all Malone racks and accessories be properly and securely attached to your vehicle. Improper attachment could result in a serious accident, and could cause serious bodily injury or death to you or to others. You are responsible for securing the racks and accessories to your car, checking the attachment's prior to use, and periodically inspecting the products for adjustment, wear, and damage.

You must read and understand all of the instructions and cautions supplied with your Malone products(s) prior to installation or use. If you do not understand all of the instructions and cautions, or, if you have no mechanical experience and are not thoroughly familiar with the installation procedures, you should have the product installed by a professional installer.

MISE EN GARDE IMPORTANTE: Tout transport d'un chargement sur le toit d'un véhicule est potentiellement dangereux. Une personne qui utilise les produits Malone doit suivre sans faute les instructions d'installation et d'utilisation fournies et assume l'entière responsabilité pour tout dommage ou toute blessure, y compris un décès, pouvant résulter d'une telle installation ou utilisation.

Il est essentiel de fixer correctement et solidement les supports et les accessoires à votre véhicule. Une mauvaise installation ou attache pourrait provoquer un accident, entraîner des blessures corporelles graves à vous et aux autres et même causer la mort. Vous avez la responsabilité de fixer solidement les supports et les accessoires à votre véhicule, de vérifier l'installation avant l'utilisation et d'inspecter périodiquement le produit pour déceler tout signe d'usure ou de dommage ou tout problème d'ajustement.

Vous devez lire et comprendre les instructions et les mises en garde fournies avec les produits Malone avant l'installation et l'utilisation. Si vous ne comprenez pas les instructions et les mises en garde ou si vous ne possédez pas d'expérience en mécanique et ne connaissez pas à fond les procédures à suivre d'installation, vous devriez faire monter et poser le produit par un installateur professionnel.

BEFORE YOU BEGIN: CONSULT FIT GUIDE FOR COMPATIBILITY

1). The roof bars have been supplied with 4 lockable clamps. The two lockable clamps marked A contain an allen key which is used to secure the roof bars to the raised roof rails on your vehicle. To access the allen key, turn the key clockwise. Pull out the key pad, you will see the allen key.

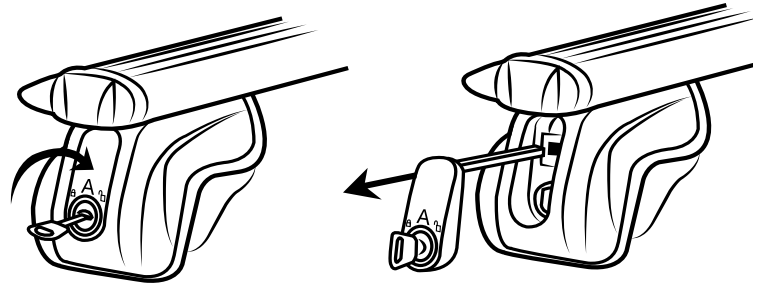

2). Remove the allen key from its storage position (the top opening). Insert the allen key into the bottom opening and twist anti-clockwise to open up the clamping area..

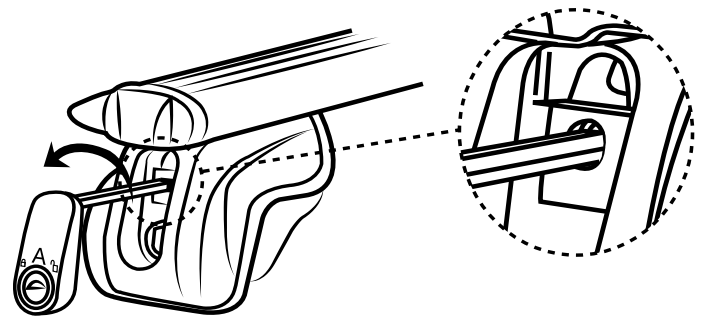

3). Position the roof bars 24" (minimum) apart on the roof rails (unless different instructions are given by the vehicle manufacturer).

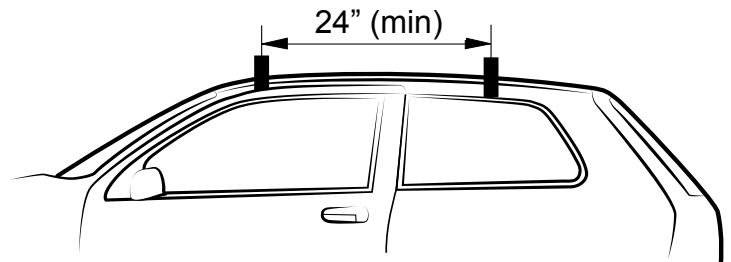

Warnings / Limitations: The load you are carrying plus the weight of the rack must not exceed the maximum weight limitation of the vehicle's factory raised side rails. Before installing, confirm your vehicle's factory specifications.

NOTE: Where items of equipment are being carried that may induce lifting forces (surfboards, sail boards, kayaks, canoes, ladders etc.) All of these types of equipment should be secured independently to the front and rear of the vehicle using tie-down straps that are capable of withstanding the lifting forces (NOT INCLUDED).

Bow and stern safety tie-downs are required for all Malone rooftop transport(s).

Failure to correctly install and use safety tie-down lines voids all warranty and liability.

- . Never assume a cross bar will fit. Always refer to Malone's Fit Guide for proper, correct and approved vehicle fit.
- . Locks must be turned periodically and lubricated to ensure smooth operation. Use of a dry lubricant is recommended.
- . Confirm that all bolts and locks are firmly secured prior to transport. Periodically check the load during transport.
- . Do not continue to use the product if excessive corrosion, deformity or any mechanical defect is detected.
- . Check local and state laws governing projection of objects beyond the perimeter of the vehicle.
- . Malone locks are designed to deter vandalism and theft but should not be considered theft proof.
- . Obey all posed speed limits and traffic cautions. Adapt your driving for the load being transported.
- . Do not use Malone cross bars for purposes other than what they were designed for.
- . Not for use on trailers or any other modes of transport other than vehicle rooftop transport.
- . Failure to follow these guidelines will void the warranty.
- . Remove the product before entering a carwash.

BEFORE YOU BEGIN: CONSULT FIT GUIDE FOR COMPATIBILITY

4). Secure the position of the clamp and twist the allen key clockwise to tighten the clamp securely onto the roof rail. Always ensure that the mounting bracket is correctly connected (see diagram A) to the roof rail. Incorrect connection (see diagrams B & C) can lead to unstable loads causing a danger to other road users.

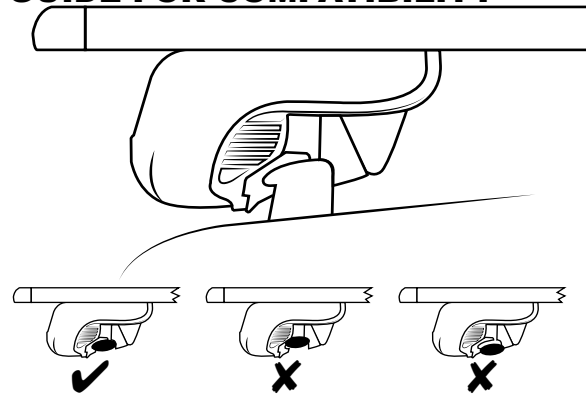

5). Remove the allen key from the bottom opening and insert it into the top opening location. Twist the key anti-clockwise and remove the key.

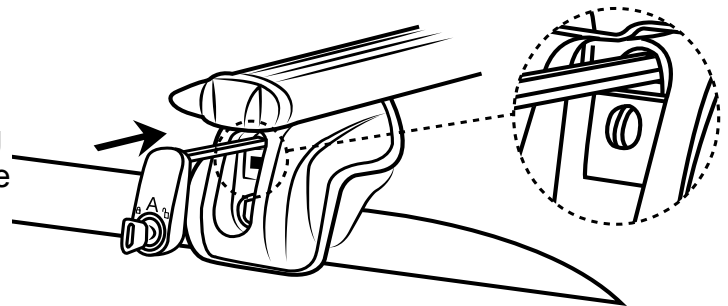

6). A U-bolt or a T-bolt (not included) are typically used when fixing other roof top items onto your roof bars. If using a T-bolt simply open the end cap, slide the T-bolt into the cavity then close the end cap.

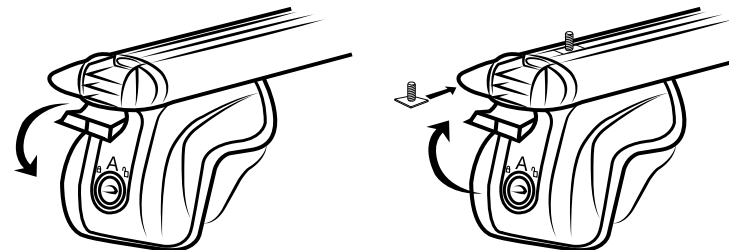

Warnings / Limitations: The load you are carrying plus the weight of the rack must not exceed the maximum weight limitation of the vehicle's factory raised side rails. Before installing, confirm your vehicle's factory specifications.

NOTE: Where items of equipment are being carried that may induce lifting forces (surfboards, sail boards, kayaks, canoes, ladders etc.) All of these types of equipment should be secured independently to the front and rear of the vehicle using tie-down straps that are capable of withstanding the lifting forces (NOT INCLUDED).

Bow and stern safety tie-downs are required for all Malone rooftop transport(s).

Failure to correctly install and use safety tie-down lines voids all warranty and liability.

- . Never assume a cross bar will fit. Always refer to Malone's Fit Guide for proper, correct and approved vehicle fit.
- . Locks must be turned periodically and lubricated to ensure smooth operation. Use of a dry lubricant is recommended.
- . Confirm that all bolts and locks are firmly secured prior to transport. Periodically check the load during transport.
- . Do not continue to use the product if excessive corrosion, deformity or any mechanical defect is detected.
- . Check local and state laws governing projection of objects beyond the perimeter of the vehicle.
- . Malone locks are designed to deter vandalism and theft but should not be considered theft proof.
- . Obey all posed speed limits and traffic cautions. Adapt your driving for the load being transported.
- . Do not use Malone cross bars for purposes other than what they were designed for.
- . Not for use on trailers or any other modes of transport other than vehicle rooftop transport.
- . Failure to follow these guidelines will void the warranty.
- . Remove the product before entering a carwash.

1). With the cross bars installed, measure the distance of the exposed slot. With scissors, trim the rubber insert to measured length.

2). From the bottom of each cross bar, press the rubber insert into the exposed slot.

Please note: This step does not effect the mechanical integrity of the cross bar. The sole purpose of the inserts is to lower wind noise during travel.

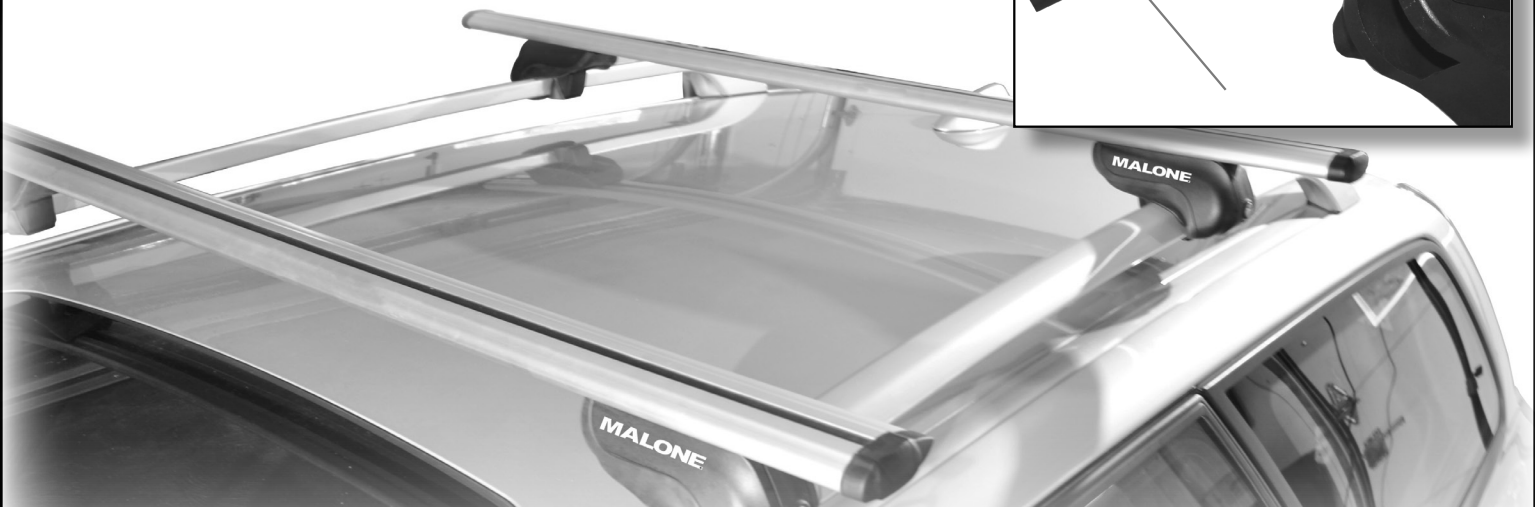
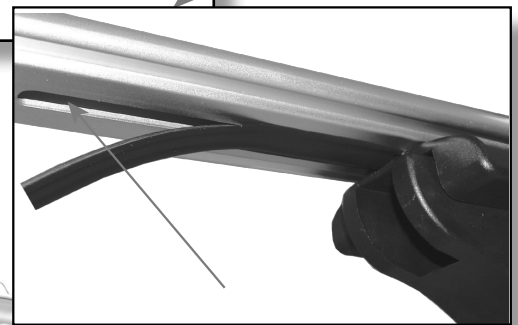
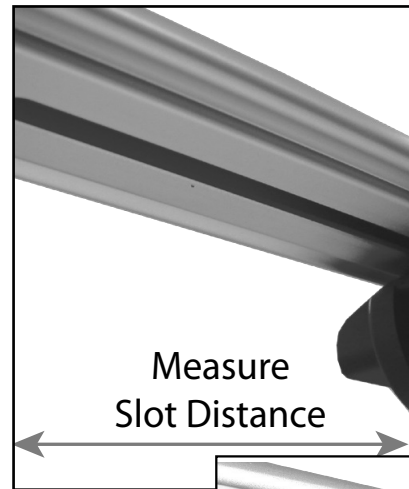

Warnings / Limitations: The load you are carrying plus the weight of the rack must not exceed the maximum weight limitation of the vehicle's factory raised side rails. Before installing, confirm your vehicle's factory specifications.

NOTE: Where items of equipment are being carried that may induce lifting forces (surfboards, sail boards, kayaks, canoes, ladders etc.) All of these types of equipment should be secured independently to the front and rear of the vehicle using tie-down straps that are capable of withstanding the lifting forces (NOT INCLUDED).

Bow and stern safety tie-downs are required for all Malone rooftop transport(s).

Failure to correctly install and use safety tie-down lines voids all warranty and liability.

- . Never assume a cross bar will fit. Always refer to Malone's Fit Guide for proper, correct and approved vehicle fit.
- . Locks must be turned periodically and lubricated to ensure smooth operation. Use of a dry lubricant is recommended.
- . Confirm that all bolts and locks are firmly secured prior to transport. Periodically check the load during transport.
- . Do not continue to use the product if excessive corrosion, deformity or any mechanical defect is detected.
- . Check local and state laws governing projection of objects beyond the perimeter of the vehicle.
- . Malone locks are designed to deter vandalism and theft but should not be considered theft proof.
- . Obey all posed speed limits and traffic cautions. Adapt your driving for the load being transported.
- . Do not use Malone cross bars for purposes other than what they were designed for.
- . Not for use on trailers or any other modes of transport other than vehicle rooftop transport.
- . Failure to follow these guidelines will void the warranty.
- . Remove the product before entering a carwash.

MALONE

CHANGING THE WAY YOU GET THERE

Limited Lifetime Warranty

The Malone Auto Racks (Malone) Limited Lifetime Warranty covers certain Malone-brand products that have been specifically identified for inclusion in the program and is effective for as long as the original retail purchaser owns the product. This warranty is terminated when the original retail purchaser sells or otherwise transfers the product to any other person or entity.

Subject to the limitations and exclusions described in this warranty, Malone will remedy defects in materials and/or workmanship by repairing or replacing, at its option, a defective product without charge for parts or labor. Malone may elect, at its option, not to repair or replace a defective product but rather issue to the original retail purchaser a refund equal to the purchase price paid for the product, or credit to be used toward the purchase of a replacement Malone product.

This warranty does not cover, and no warranty is given for defects or problems caused by normal wear and tear, which includes, but is not limited to, surface (aesthetic) metal corrosion, scratches, dents, deformities, accidents, unlawful vehicle operation, or any modification of a product not performed or authorized in writing by Malone.

In addition, this warranty does not cover problems resulting from conditions beyond Malone's control including, but not limited to, theft, misuse, overloading, or failure to assemble, mount or use the product in accordance with Malone's written instructions or guidelines included with the product provided to the original retail purchaser.

No warranty is given for Malone products purchased outside of the continental United States, Canada and Mexico.

If the product is believed to be defective, the original retail purchaser should contact the Malone dealer from whom it was purchased, who will give the original retail purchaser instructions on how to proceed. If the original retail purchaser is unable to contact the Malone dealer, or the dealer is not able to remedy the defect, the original retail purchaser should contact Malone by email at support@maloneautoracks.com.

In the event that the product must be returned to Malone, a technician at the email address above will provide the original purchaser with return shipping instructions. The original purchaser will be responsible for the cost of mailing the product to Malone. In order to be eligible to receive any remedy under this warranty, a copy of the original purchase receipt, a description of the defect and a return address must be provided.

Disclaimer of Liability

Repair or replacement of a defective product, or the issue of a refund or credit (as determined by Malone) is the original retail purchaser's sole and exclusive remedy under this warranty. Damage to original purchaser's vehicle, cargo, or property, and/ or to any other person or property is not covered by this warranty.

This warranty is expressly made in lieu of any and all other warranties, express or implied, including the warranties of merchantability and fitness of a particular purpose

Malone's sole liability to any purchaser is limited to the remedy set forth above. In no event will Malone be liable for any direct, indirect, consequential, incidental, special, exemplary, or punitive damages , or, for any other damages of any kind or nature (including but not limited to, lost profits, lost income or lost sales).

Some states do not allow the exclusion or limitation of incidental or consequential damages, so the above limitations may not be applicable.

In addition, all vehicular transports are potentially hazardous. Any person(s) using Malone products are personally responsible for following the given directions for use and/or installation and accepts full responsibility for any and all damages or injury of any kind including death, which may result from their use and/or installation.

MALONE AUTO RACKS 81 County Rd. Ste 1, Westbrook, ME 04092
P: 207.774.9100 F: 207.615.0551
E: support@maloneautoracks.com W: www.maloneautoracks.com

MALONE

CHANGING THE WAY YOU GET THERE

Garantie à vie limitée

La garantie à vie limitée de Malone Auto Racks (Malone) couvre certains produits de marque Malone expressément désignés pour être inclus dans ce programme et est valide tant que l'acheteur original est propriétaire du produit. Cette garantie prend fin lorsque l'acheteur original vend ou cède le produit à une autre personne ou entité.

Sous réserve des restrictions et exclusions prévues dans la garantie, Malone corrigera toute défectuosité matérielle et/ou tout défaut de fabrication en réparant ou en remplaçant, à sa discrétion, un produit défectueux sans frais pour ce qui est des pièces et de la main-d'oeuvre. Malone peut décider, à son choix, de ne pas réparer ou remplacer un produit défectueux, mais plutôt d'accorder à l'acheteur original un remboursement d'un montant égal au prix d'achat pour le produit ou encore un crédit pour l'achat d'un produit de remplacement de marque Malone.

La présente garantie ne couvre pas les défauts et les problèmes résultant d'une usure normale et aucune garantie n'est offerte à cet égard, notamment en cas de corrosion du métal en surface (esthétique), d'égratignures, de bosses, de déformations, d'accident, d'une utilisation illégale du véhicule ou de toute modification du produit qui n'est pas effectuée ou autorisée par écrit par Malone.

En outre, la garantie ne couvre pas les problèmes résultant de circonstances échappant au contrôle de Malone, y compris, notamment, résultant d'un vol, d'un usage abusif ou d'une surcharge ou encore d'un assemblage, d'une installation ou d'une utilisation du produit ne respectant pas les instructions écrites de Malone fournies à l'achat à l'acheteur original.

Aucune garantie n'est offerte pour des produits Malone achetés à l'extérieur du territoire continental des États-Unis, du Canada ou du Mexique.

Si le produit semble défectueux, l'acheteur original doit contacter le détaillant Malone où il a fait son achat et celui-ci lui fournira des renseignements sur la démarche à suivre. Si l'acheteur original ne réussit pas à contacter le détaillant Malone ou encore si le détaillant est incapable de remédier à la défectuosité, l'acheteur original doit communiquer directement avec Malone par courriel à l'adresse suivante : support@maloneautoracks.com.

Dans le cas où le produit doit être retourné à Malone, un technicien contacté à l'adresse courriel ci-dessus fournira à l'acheteur original les instructions à suivre pour l'expédition du produit. L'acheteur original devra assumer les frais d'expédition à Malone. Pour qu'une demande soit admissible aux termes de la présente garantie, il faut envoyer à Malone une copie du reçu de l'acheteur original, une description de la défectuosité et une adresse de retour.

Exonération de responsabilité

La réparation ou le remplacement du produit défectueux ou encore la remise d'un remboursement ou d'un crédit (tel que déterminé par Malone) constitue le seul et exclusif dédommagement offert à l'acheteur original aux termes de la présente garantie. Les dommages causés au véhicule de l'acheteur original, à un chargement, à ses biens et/ou à toute autre personne ou tout autre bien ne sont pas couverts par cette garantie.

Cette garantie est octroyée expressément afin de remplacer toute autre garantie expresse ou implicite, y compris toute garantie de qualité marchande ou de conformité pour un usage particulier.

L'unique responsabilité de Malone envers l'acheteur se limite aux dédommagements indiqués ci-dessus. Malone ne pourra en aucun cas être tenu responsable des dommages directs, indirects, consécutifs, spéciaux, exemplaires ou punitifs ou de tout autre dommage de quelque nature que ce soit (y compris notamment une perte de profits, de revenus ou de ventes).

L'exclusion ou la limitation des dommages indirects ou consécutifs n'étant pas permise à certains endroits, les limitations indiquées ci-dessus peuvent ne pas s'appliquer.

En outre, tous les transports par véhicule comportent des risques potentiels. Toute personne utilisant un produit Malone est donc personnellement responsable de suivre les instructions fournies pour son utilisation et/ou son installation et accepte l'entière responsabilité pour tout dommage ou toute blessure de quelque nature que ce soit, y compris un décès, pouvant résulter de son utilisation et/ou son installation.

MALONE AUTO RACKS 81 County Rd. Ste 1, Westbrook, ME 04092

P: 207.774.9100 F: 207.615.0551

E: support@maloneautoracks.com W: www.maloneautoracks.com