

# MALONE®

## ***\*ATTENTION CUSTOMERS\****

Thank you for your recent purchase of a Malone trailer.

***Please inspect all parts and hardware bags prior to assembly.***

***\*Important documents may come directly from the dealer you've purchased the trailer from.***

***\*\* IF your trailer includes a large red envelope (found in the axle box), place the envelope containing important documents in a safe spot.***

If you encounter damage of any packaging or parts, or find that parts are missing - please email us with photos and your Proof of Purchase at:

Email: [support@maloneautoracks.com](mailto:support@maloneautoracks.com)

For the most updated instruction manual scan the QR Code here:



For the trailer support and accessory fit guide scan the QR Code here:



Thank you from all of us at Malone

**CHANGING THE WAY YOU GET THERE**

# MALONE<sup>®</sup>

**CHANGING THE WAY YOU GET THERE**

## Important Note

### Product Warranty & Registration Form

All information is confidential and used exclusively by MALONE only.

Dear Customer,

Thank you for your purchase of a Malone Product.

In order to be eligible for the Malone Warranty program, we ask that you contact us online at the link provided below within 30 days of purchase. You can also mail this letter back to the address at the bottom.

- Online: <https://maloneautoracks.com/product-registration.php>

We will require the information below.

Here is the information collected:

First Name: \_\_\_\_\_

Last Name: \_\_\_\_\_

Address: \_\_\_\_\_

Address2: \_\_\_\_\_

City: \_\_\_\_\_

State: \_\_\_\_\_

Zip: \_\_\_\_\_

Country: \_\_\_\_\_

Email: \_\_\_\_\_

Phone: \_\_\_\_\_

Product Description/Name: \_\_\_\_\_

Product MPG#: \_\_\_\_\_

Date Purchased: \_\_\_\_\_

Store Where Purchased: \_\_\_\_\_

Purchase Price: \_\_\_\_\_

**Thank you for choosing Malone!**

*Please Note: Registration Form is not a valid Proof of Purchase. Please retain your original receipt for any future warranty claims.*

# MALONE<sup>®</sup>

## TRAILERS

### MicroSport™ Series

*Combined Assembly Instructions*

*Base Model#s*

MPG460G & MPG440BLK



MPG460G



MPG440BLK

*LowBed™ Model#s*

MPG464LB & MPG444LB-BLK

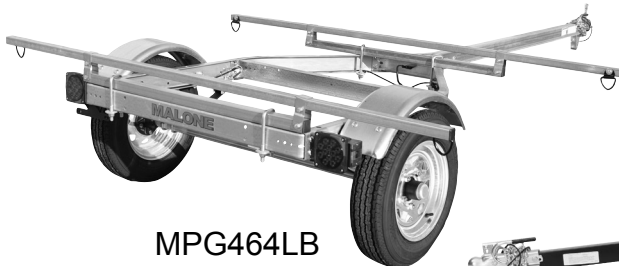

MPG464LB



MPG444LB-BLK

## CHANGING THE WAY YOU GET THERE

Take a few moments and read through these instructions to familiarize yourself with the step by step assembly process before you begin turning wrenches.

Unpack and sort the components into groups as shown in the following pages.

Then assemble each group in order. Lets get started !!

### Required Tools:

- (2) 3/4" wrenches • (2) 9/16" wrenches (a deep socket is recommended)
- Large flat blade screw driver • 7/16" wrench • 3/8" wrench and socket
- 13/16" socket • Large Phillips head screw driver • Rubber hammer

Bag 11462

Group 1:  
Frame  
Components

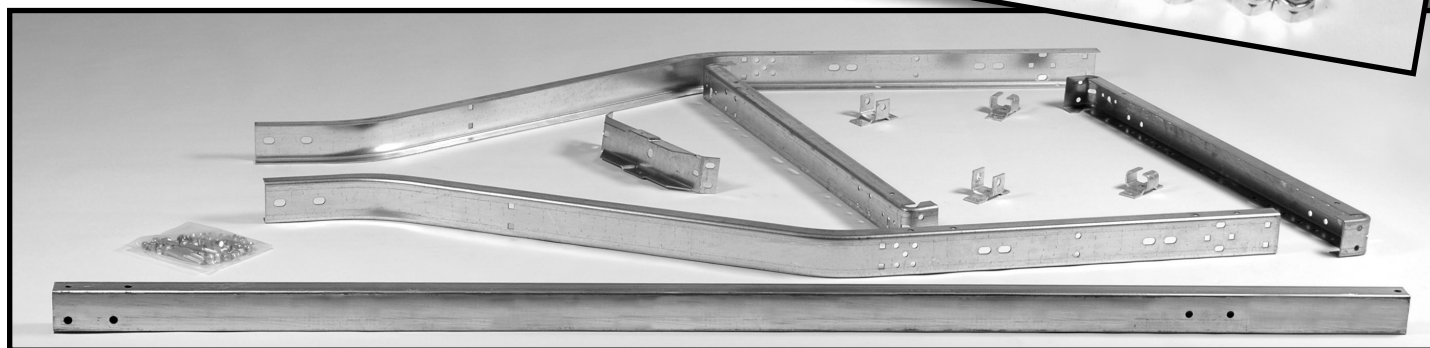

Group 2:  
Axle / Spring  
Components

Bag 11476

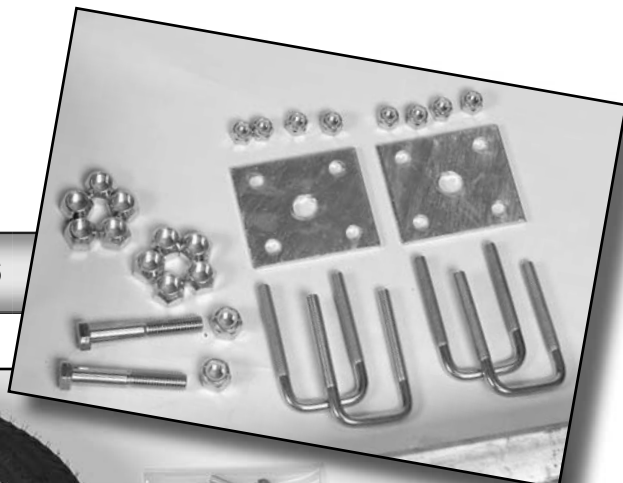

Group 3: Lighting Components

Bag 11468



Group 4:  
Fender Components

Bag 11464

**\*NOTE: Image for reference only.**

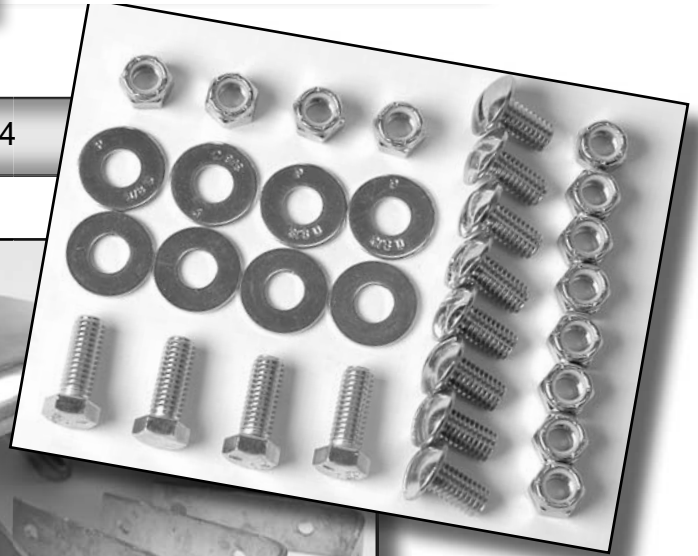

Group 5: Coupler Components

Bag 11494



Visit [www.maloneautoracks.com/Replacement-Parts](http://www.maloneautoracks.com/Replacement-Parts)  
for all of your spare part needs

**Group 6:  
Load Bar  
Components**

Bag HDW/BKTS

*\*Use Black U-Bolts for  
MPG440BLK & MPG444LB-BLK*

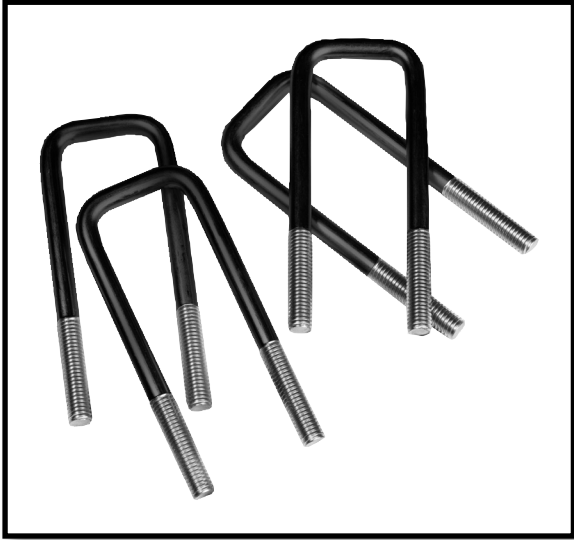

*Base Series Load Bars  
MPG460G & MPG440BLK*

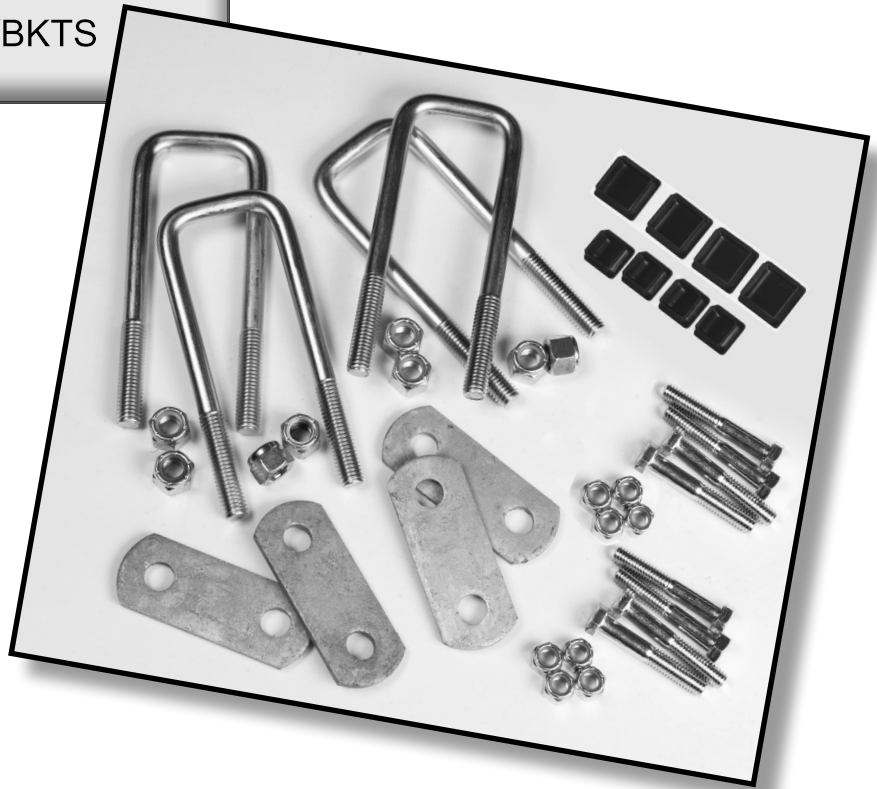

*LowBed™ Series Load Bars  
MPG464LB & MPG444LB-BLK*

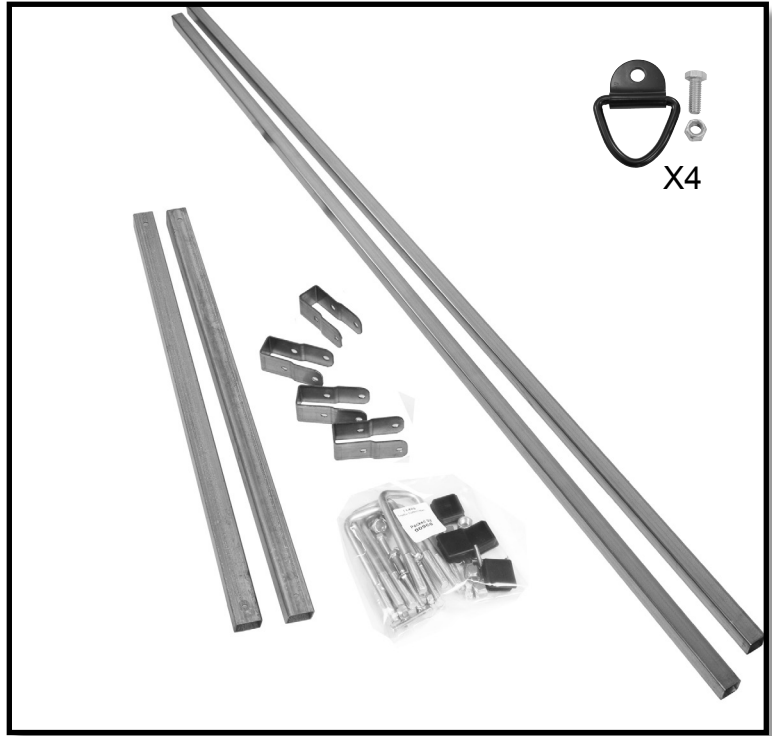
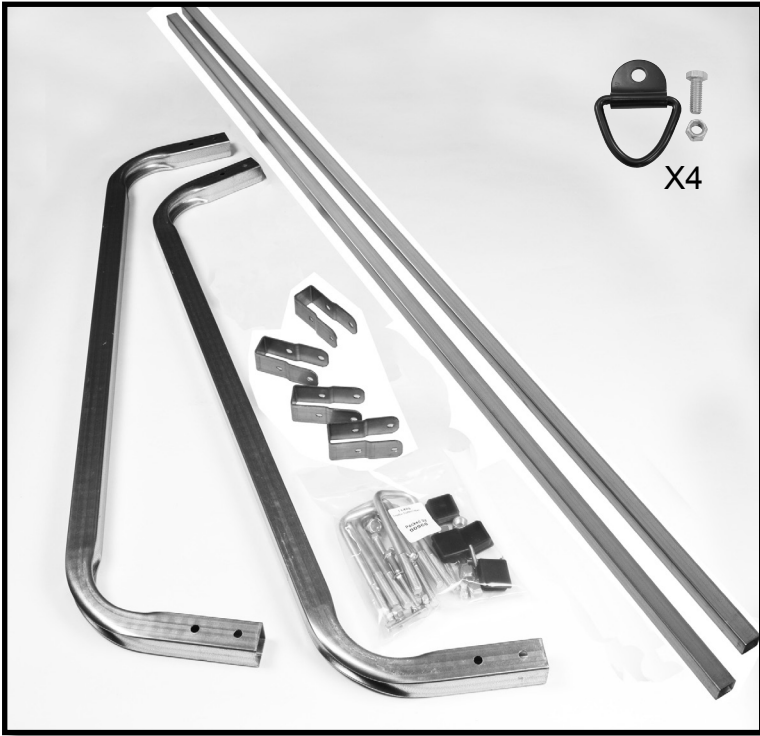

1. We assemble the frame 'on its back' to make it easier to install the springs and axle. Once the spring and axle assembly is installed we will flip the trailer over to complete the assembly. So first, layout the components as shown. The side rails are symmetrical and work on both sides. There is No top or bottom. The cross members are symmetrical also and can be placed as shown.

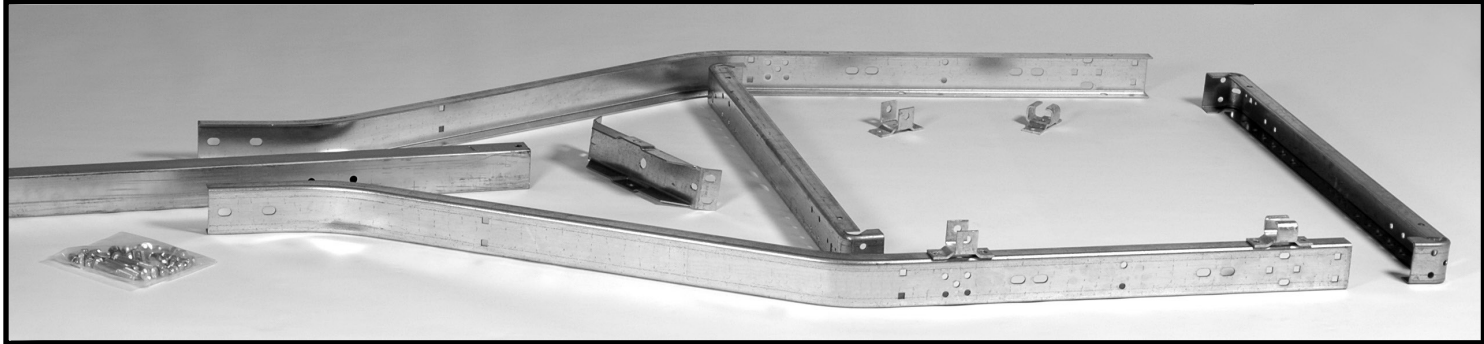

2. Attach the spring hanger brackets to the frame. The U shaped shackle bolt brackets mount to the front and the C shaped "slipper" brackets mount to the rear as shown. Use 3/8" x 1" bolts and nuts. Assemble with the nuts on the inside of the frame rails. Fully tighten all 8 bolts now.



3. Identify the hitch end of the tongue by the 3 holes on the left (drivers) side.

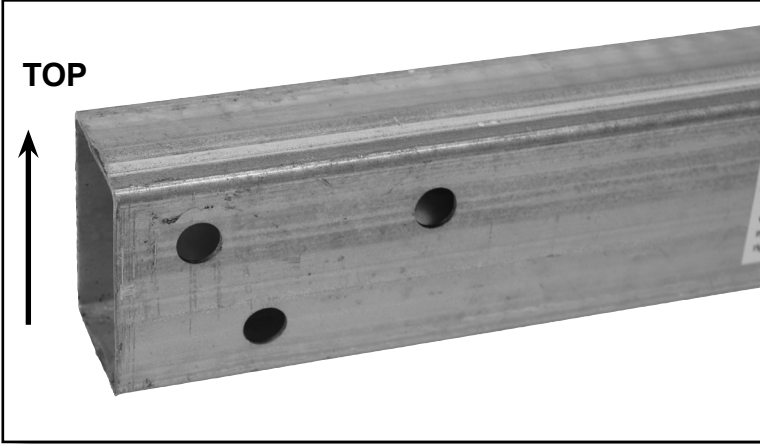

4. Pass the wiring harness (with a plug at each end), into the open end of the tongue, leaving enough excess at the front to reach the vehicle. NOTE: MAKE SURE YOUR PLUG MATCHES THE VEHICLE CONNECTION. IF NOT REVERSE YOUR WIRING HARNESS NOW.

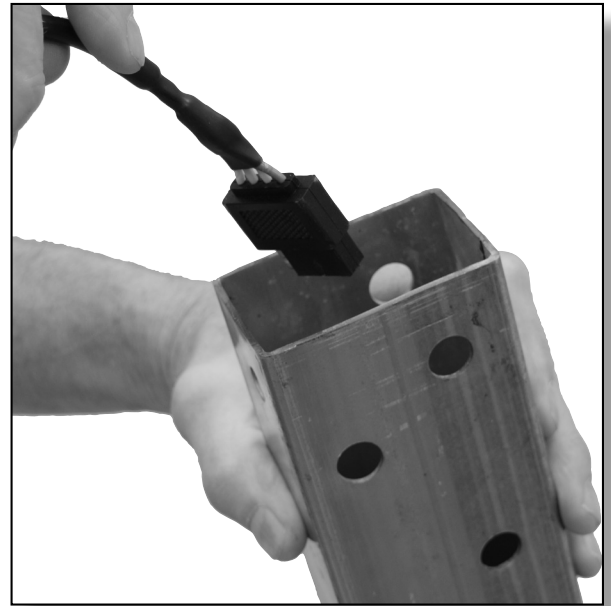

5. Installing the rear tongue support bracket. First we lay the tongue back in its place making sure it's upside down. Pass the wiring through the support bracket hole.

6. Install the 4-1/2" long x 1/2" bolt up from the bottom through the tongue support and tongue. Be careful not to pinch the wires. Add washer and nut. Hand tighten only.

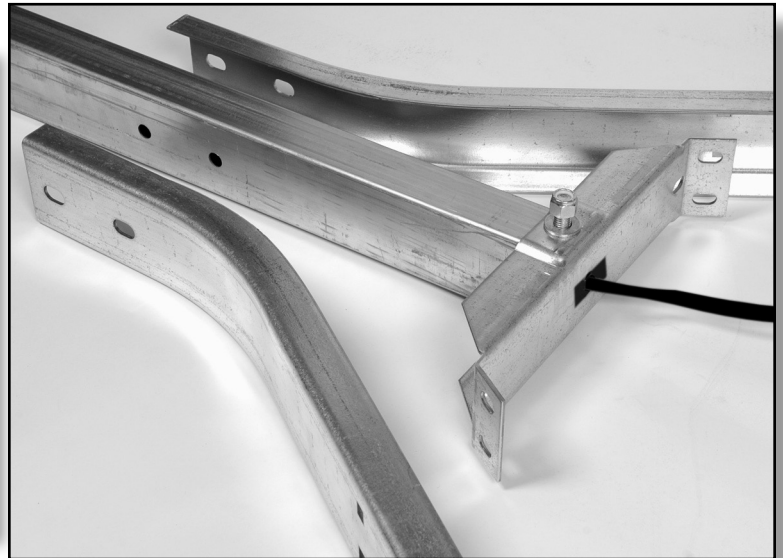
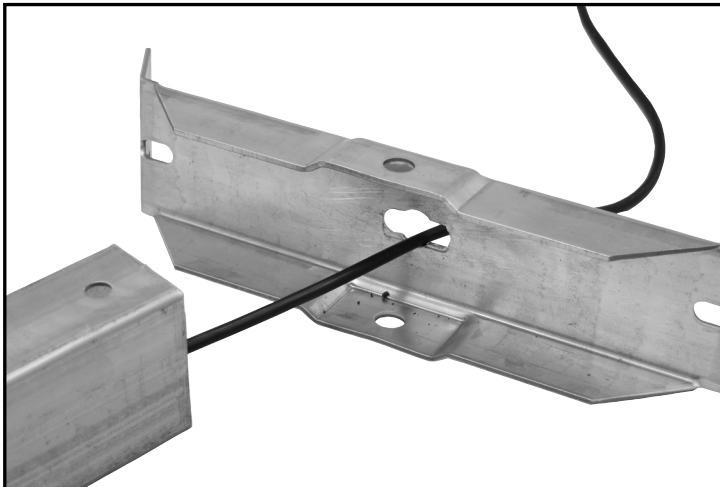

7. Bolt the tongue support to the frame rails using 3/8" x 1" carriage head bolts. Note the square heads go on the outside with the square holes in the frame. Assemble with washers and nuts on the inside.

8. Hand tighten only.



9. Clamp the frame rails around the tongue as shown using two 1/2" x 3-1/4" bolts. Use a washer on both sides. Hand tighten only.

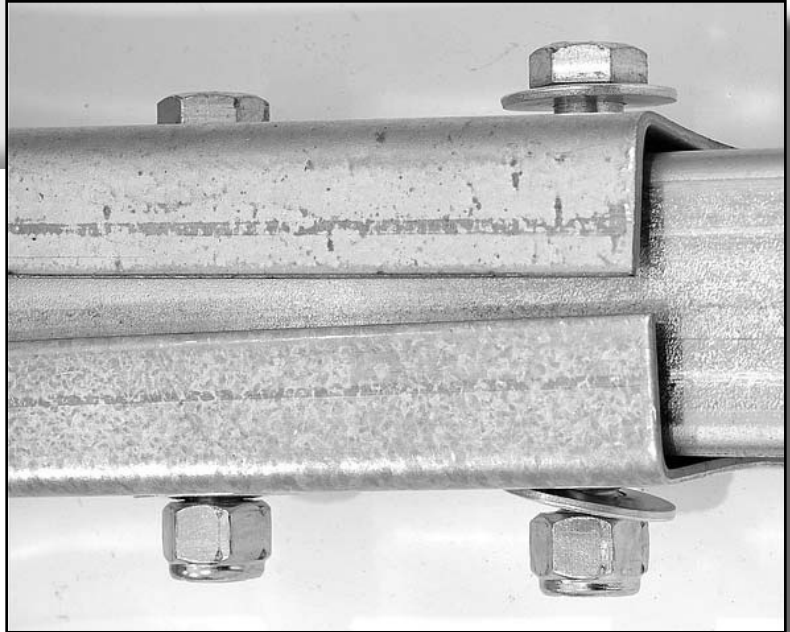

10. Lay the two frame cross members in between the frame rails. Bolt the frame rails to the cross members using 3/8" x 1" carriage bolts and nuts, (no washers). The square heads go to the outside with the square holes in the frame rails. Hand tighten only



## 11. TIME TO TIGHTEN

**FRAME BOLTS:** Its *important* to follow this tightening sequence in order to insure the trailer will be straight after everything is tight.

A) Tighten the 8 nuts holding the ends of the two cross members.

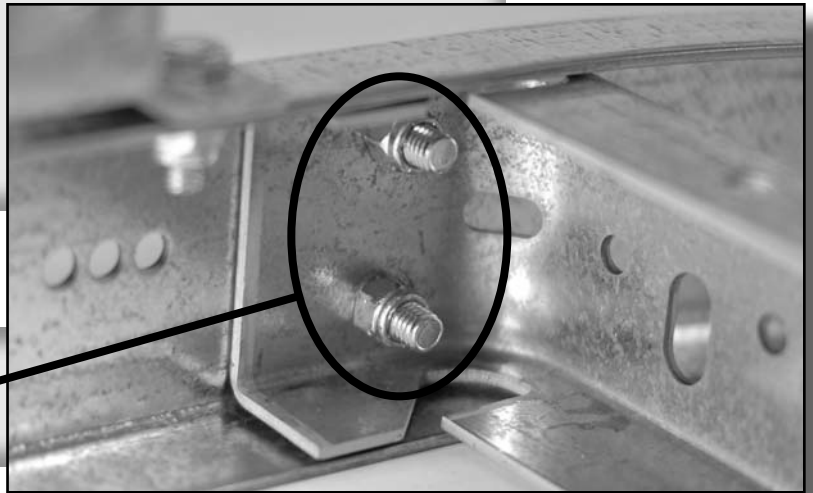

B) Tighten the rear tongue support bracket. Check that you install washers under the 4 nuts as shown. Evenly tighten the 4 nuts.

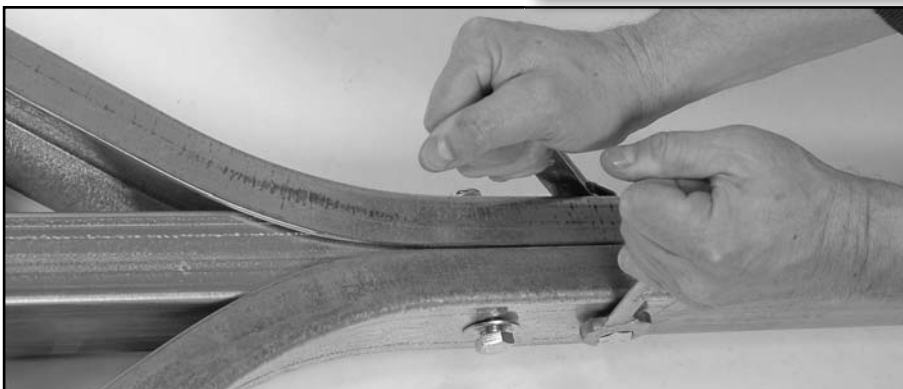
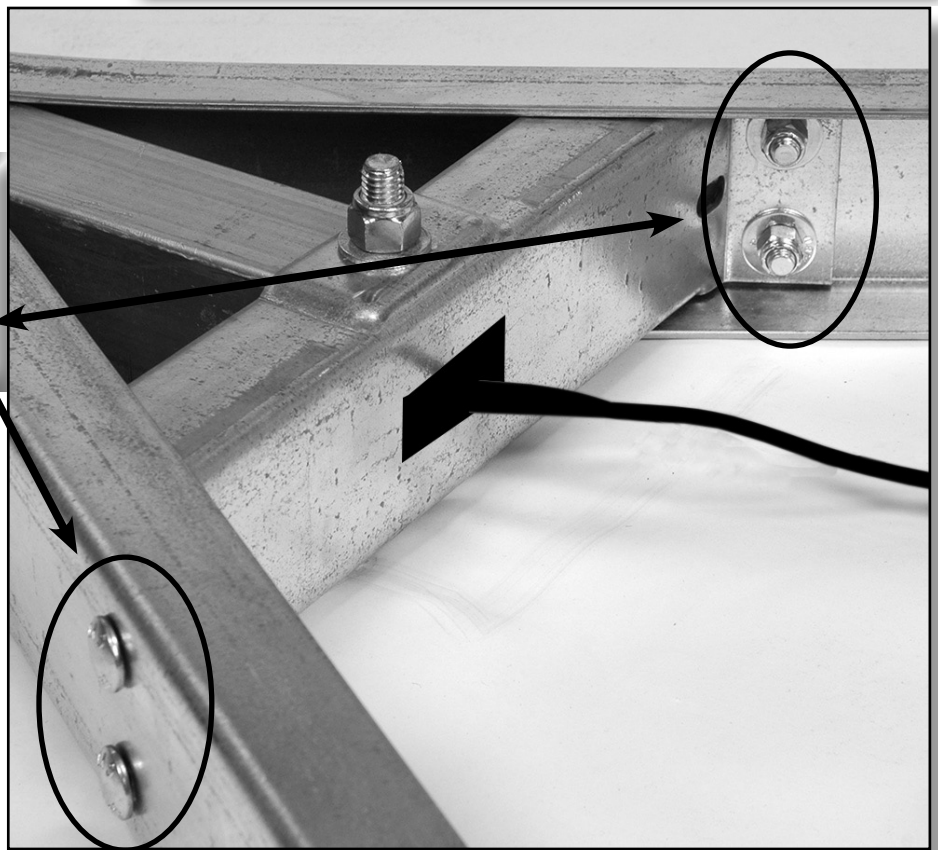

C) Tighten the two tongue bolts snug to the frame rails.

DON'T overtighten, you will just crush the tongue.

D) Tighten the big bolt through the rear of the tongue and tongue support. Not too tight, don't crush the tongue or support.

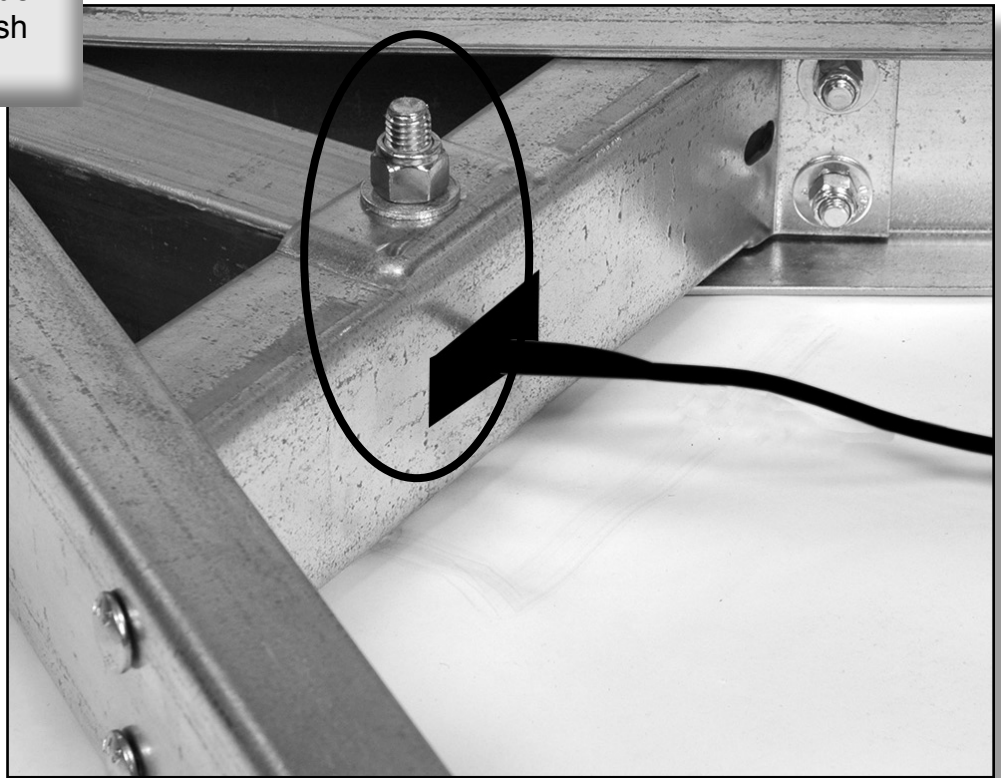

Your frame assembly is now complete and should look like this.



**SPRING AND AXLE ASSEMBLY (Group 2) MPG460G, MPG440BLK, MPG464LB, MPG444LB-BLK**

1. \*Set the large red envelope (in the axle box) containing important documents in a safe spot.

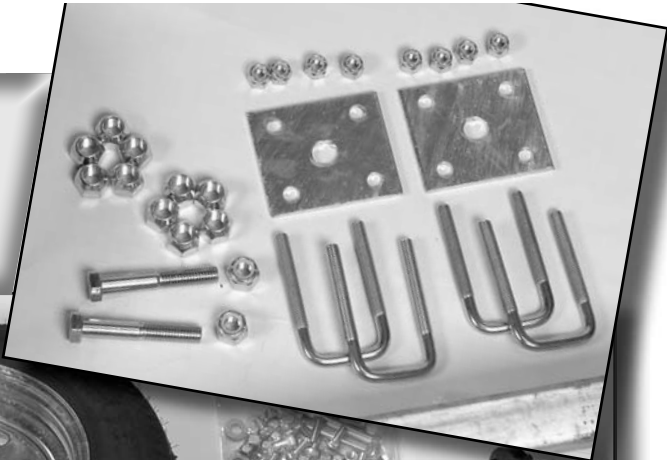

2. Spin the axle to find the side with the spring centering holes. These holes mate with the spring center stud.

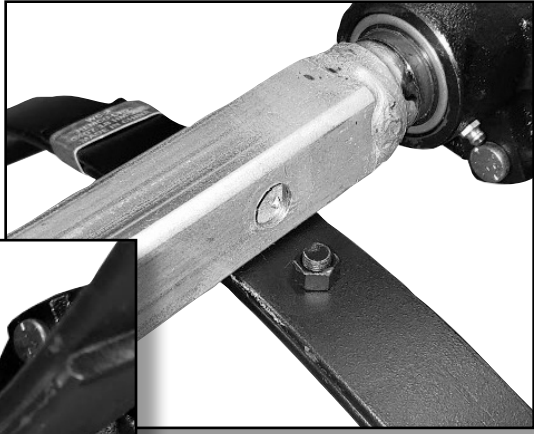

3. Lay the springs on top the axle with the centering studs in the holes in the axle. Then assemble the U-bolts, tie plates and nuts as shown. Make sure both springs are facing the same way!

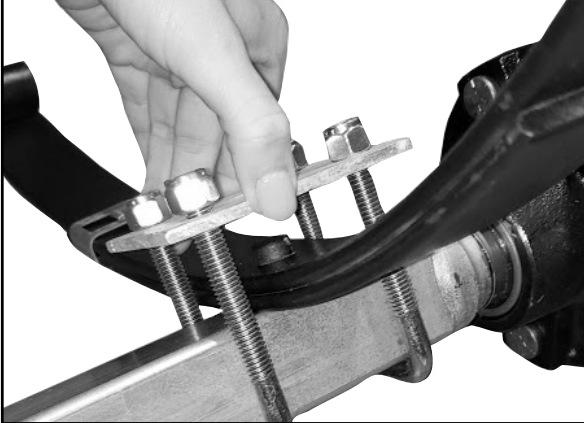

4. Run each nut down UNTIL IT TOUCHES THE PLATE ONLY! DON'T TIGHTEN!!

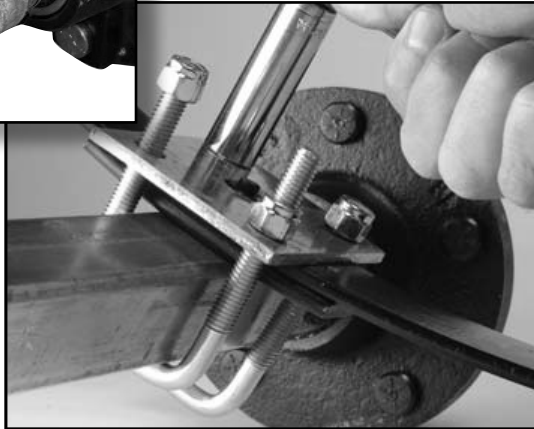

You will need to wiggle the springs to fit them into the spring brackets in the next step.

**NOTE: Images for reference only. Following these steps will insure proper installation.**

5. Lift the axle/spring assembly to the trailer frame and slide the slipper spring ends into the slipper spring brackets. Then let the spring eyes down into the front hangers.

6. Install the shackle bolts with the nuts to the inside and tighten until firm. Do not over tighten which would bend the spring hanger in and pinch the spring.

7. Fully tighten the 4 front spring hanger mounting bolts.

8. Fully and evenly tighten the 8 axle U-bolts.

9. Install the wheels on the hubs with the valve stems facing out and install and finger tighten the lug nuts. **NOTE: Tapered end on lug nut goes towards rim.**

10. Lift the trailer at one rear corner and roll it over onto the tires.

**ALWAYS BEND FROM YOUR KNEES WHEN LIFTING. IF THE TRAILER IS TOO HEAVY FOR YOU TO FLIP SAFELY RECRUIT SOME FRIENDS TO ASSIST YOU.**

11. Tighten the lug nuts firmly to 75 to 85 foot pounds of torque.

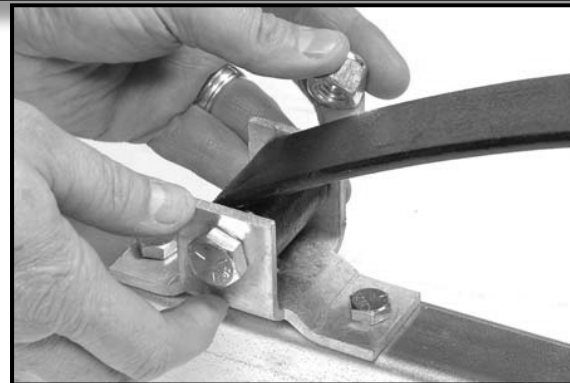

**NOTE: Images for reference only.  
Following these steps will insure proper installation.**

### **\*THINK YOU MAY HAVE A LEAKING HUB?**

It has been noted that on the first few trips the excess grease can work its way the back side of the hub, making a mess on the wheel. We have confirmed with CE Smith, to whom we sent an axle showing this issue in the past, that there is no concern with the hub or seals at all. It is simply an over packed hub, no damage to any parts within. We have seen this several times over the years but felt we may have misdiagnosed the problem. We did not and it is not a problem at all. If this incident occurs, it is not a cause to worry. Again, as we have always stated, CE Smith packs those hubs full of grease to ensure no initial maintenance is needed. Both Malone and CE Smith stand behind this.

We also received feedback from another consumer to whom we passed this information onto: "I figured this might be the situation as during a 1,200 mile drive to Colorado the hubs never overheated. I checked them every stop with an infrared thermometer. "

If you have any further questions please don't hesitate to ask.

### **LIGHT ASSEMBLY (Group 3)**

#### **L.E.D. REFERENCE:**

#### **Trailer Wiring Color Code**

- Brown = running lights
- Yellow = left turn / left brake
- Green = right turn / right brake
- White = ground



1. First attach the taillight brackets to the frame as shown using 3/8" x 1" carriage head bolts and nuts. No washers are needed.
2. Mount the taillights to the light brackets using the nuts provided with the light kit. \*Making sure to Attach/secure the license plate holder to the backside of the drivers side lamp bracket as shown.
3. Use the 5 hole pattern just above the spring bracket to mount the amber side lights. First, push the wire leads through the outside holes and the lamp stud through the center hole.
4. With the wires passed through the frame, secure with the lamp stud nut.

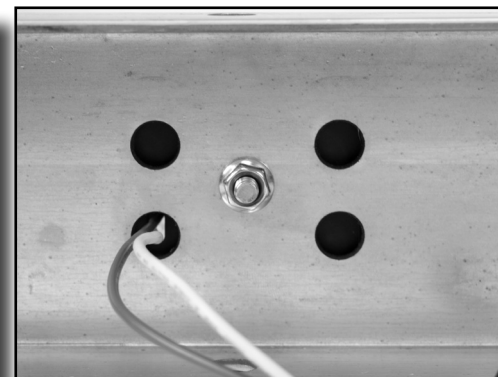
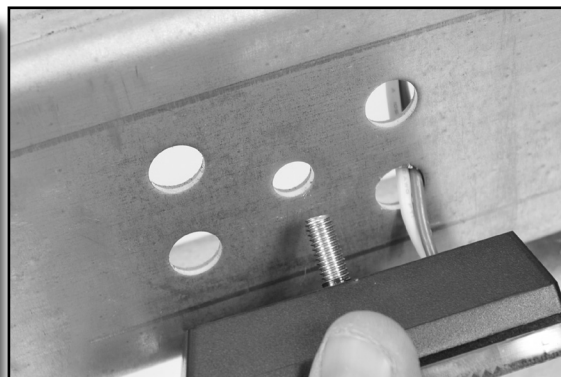

5. Plug in the remaining wiring harness into the connection behind the tongue. Looking at the end connections, route the GREEN/BROWN/WHITE wire along the passengers side. Route the YELLOW/BROWN/WHITE along the drivers side as shown.

6. Next, we'll route the wires through the cross members, One lead at a time, all the way through the trailer to the tail lights.



7. With the wires routed all the way to the tail lights, firmly grasp the wiring connections and plug-in matching colored leads/wires. Repeat with all remaining lights.

8. Use the clips provided to secure the wire to the inside of the frame channel as shown.

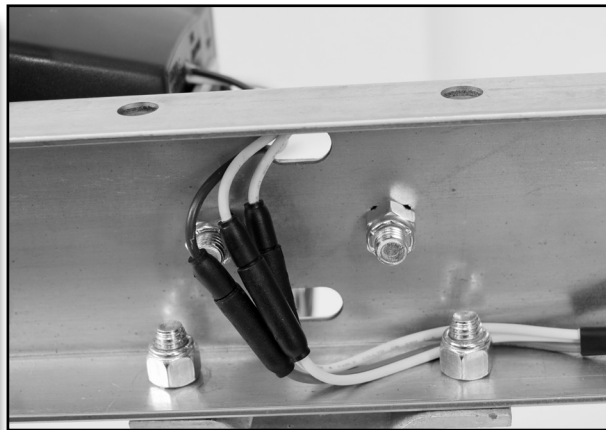
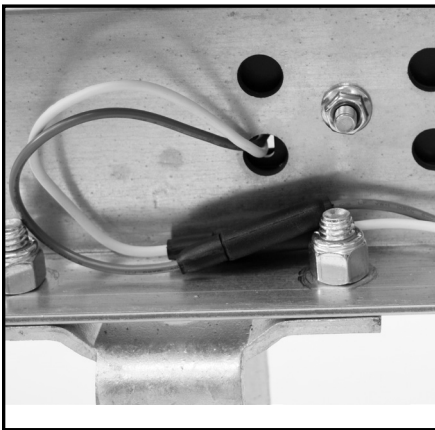

NOTE:  
UNUSED PLUGS ARE FOR AUXILIARY  
ACCESSORIES LIKE THE MALONE MPG543  
CHARGING UNIT. (NOT INCLUDED)



# \*FENDER ASSEMBLY (Group 4) - MPG460G & MPG464LB



1. Connect all 4 fender brackets to the fenders using 3/8" x 3/4" slot head screws and nuts. Assemble with the nuts to the inside of the fenders as shown. No washers here. Fully tighten all 8 screws and nuts.

**Note:** fenders are symmetrical and fit on either side of the trailer. Install trick shown here.



2. Using the **Middle hole** and the 3/8" x 1" bolts, attach the fender brackets to the \*slotted holes in the frame as shown. Secure with nylon nuts. Place washer under nut.

**Note:** that when bolting the mounting brackets to the frame you will install a washer on the inside of the frame rail, under the nut.

3. Tighten bolts fully and repeat for other side.



*\*Utilize the outer slotted holes as pictured.*

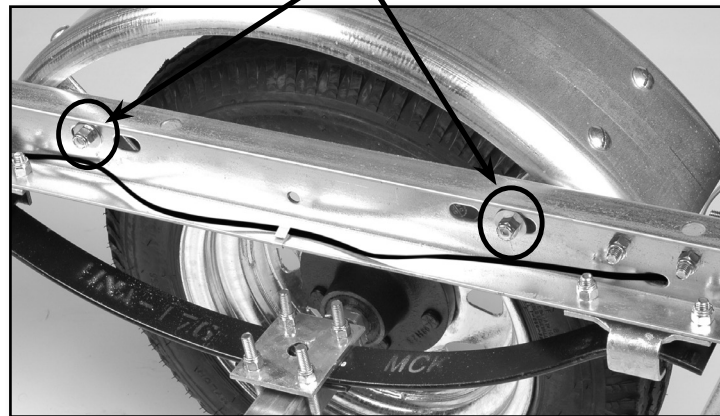

**\*FENDER ASSEMBLY (Group 4) - MPG440BLK & MPG444LB-BLK**



1. Connect all 4 fender brackets to the fenders using 3/8" x 3/4" slot head screws and nuts. Assemble with the nuts to the inside of the fenders as shown. No washers here. Fully tighten all 8 screws and nuts.

**Note:** fenders are symmetrical and fit on either side of the trailer. Install trick shown here.

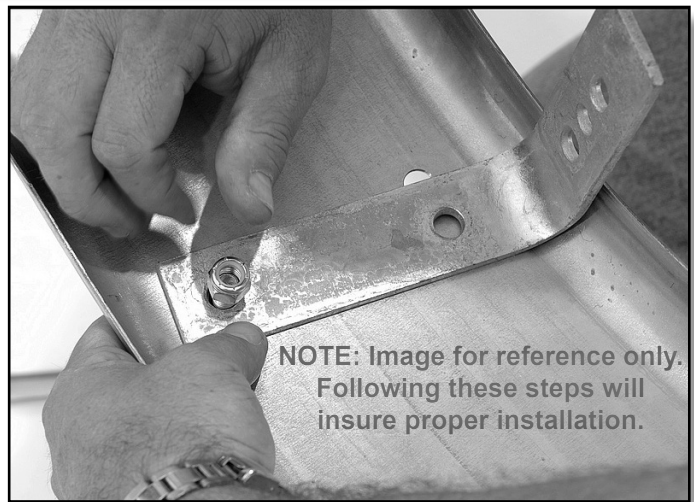

NOTE: Image for reference only. Following these steps will insure proper installation.

2. Using the **Lower hole** and the 3/8" x 1" bolts, attach the fender brackets to the \*slotted holes in the frame as shown. Secure with nylon nuts. Place washer under nut. **Using the upper mounting hole will result in the fender being too low, causing tire and fender damage.**

**Note:** that when bolting the mounting brackets to the frame you will install a washer on the inside of the frame rail, under the nut.

3. Tighten bolts fully and repeat for other side.

*\*Utilize the inner slotted holes as pictured.*

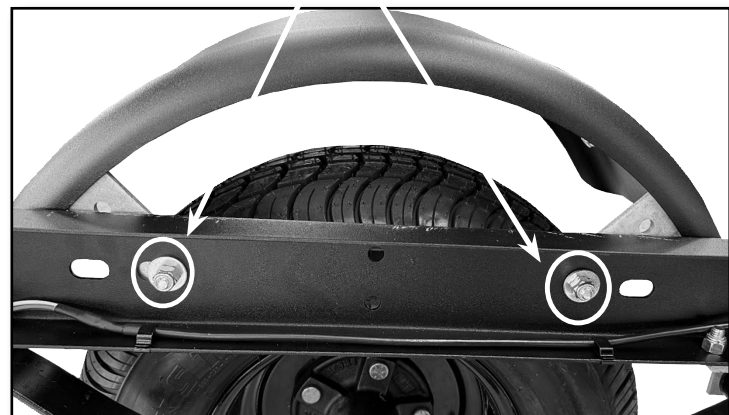
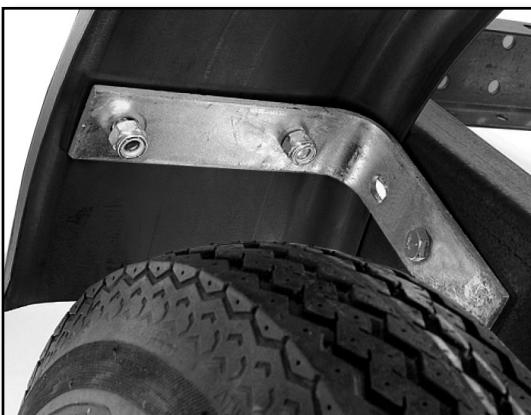

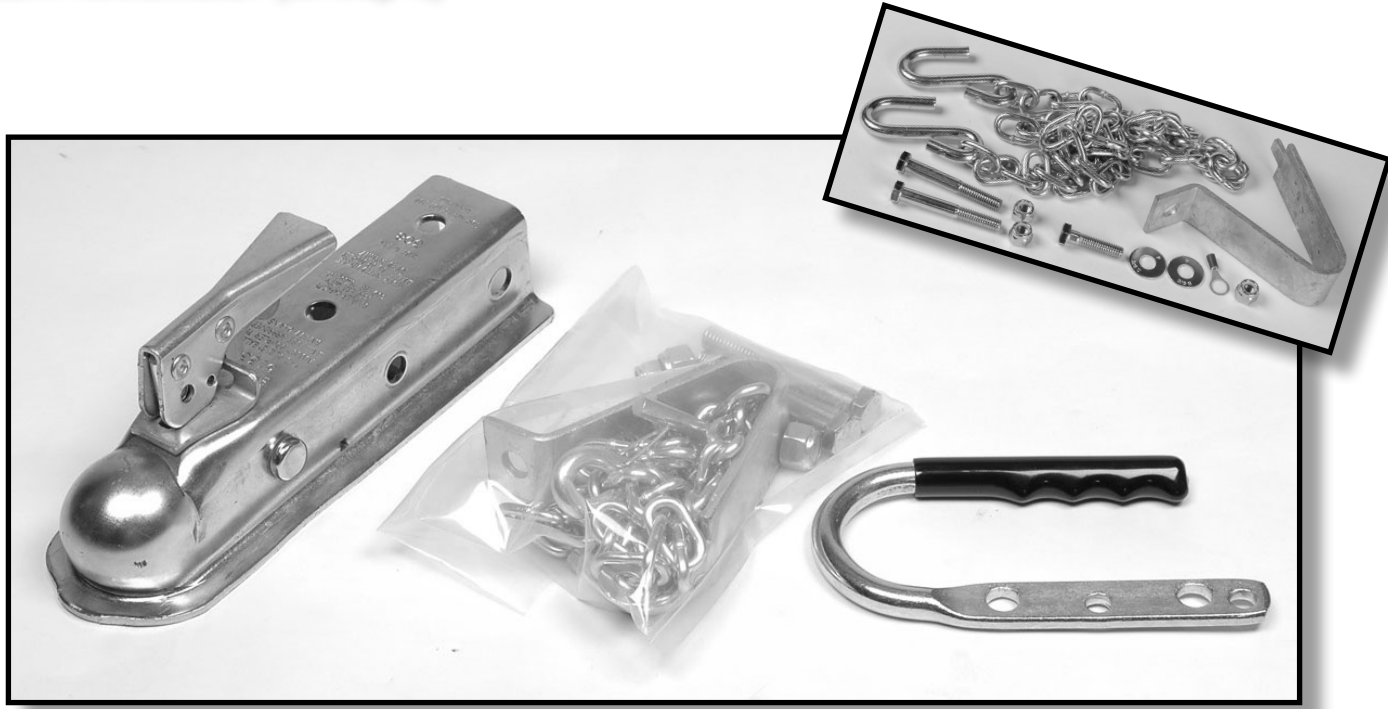

1. Assemble the tongue skid and safety chain assembly with a 3/8" x 1-1/2" bolt as shown. Use washers above and below the chain ends.
2. Place the skid and chain assembly under the tongue and insert the bolt up through the skid bolt hole on the bottom of the tongue as shown.
3. Slip the nylon lock nut over the bolt and hand tighten.
4. Check that the rear end of the skid is still in its hole in the bottom of the tongue. Fully tighten the bolt and lock nut.
5. Install the coupler and coupler handle onto the tongue as shown. Then tighten until the coupler firmly grips the tongue. Don't over tighten and crush the tongue.

**NOTE: OVER TIGHTENING WILL PREVENT THE COUPLER LATCH FROM FUNCTIONING PROPERLY.**



# LOAD BAR ASSEMBLY (Group 6)

MPG460G, MPG440BLK, MPG464LB, MPG444LB-BLK

## *Base Model#s* MPG460G & MPG440BLK

1. Attach a load bar support tube onto the rear cross member. Center the load bar and secure with the U-bolt and tie plate underneath as pictured below.
2. Attach the second support tube 48 inches forward. Measure 48 inches on both sides of the trailer to be sure the load bar is straight and centered, then tighten the U-bolts.

*\*Use Black U-Bolts for  
MPG440BLK & MPG444LB-BLK*

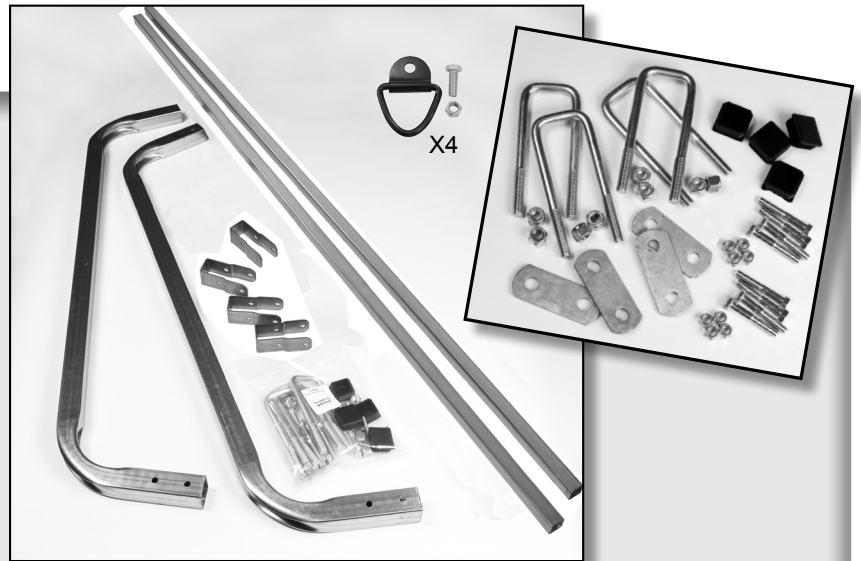

3. Use your hammer and carefully pound the end caps into the ends of the support tubes.
4. Slip the new load bar brackets over the new load bars (as shown) and loosely install the two small bolts / nuts through each bracket trapping the load bars inside the brackets.
5. Install and hand tighten the bolts holding each bracket to the support tube.
6. Center the load bars to the trailer, then tighten all 8 bracket bolts.

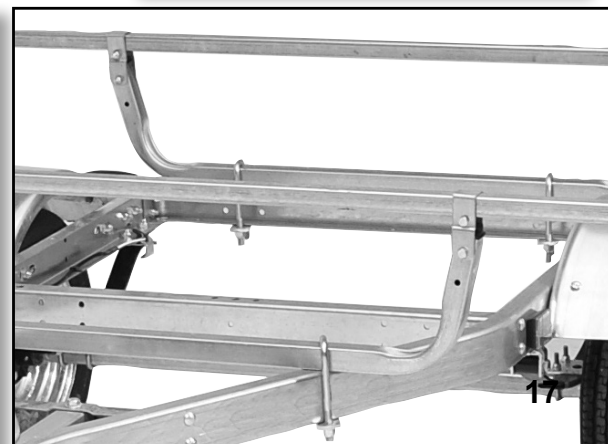
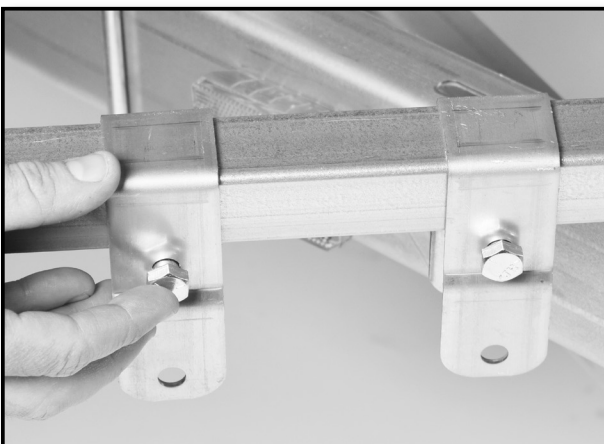

## *LowBed™ Model#s* MPG464LB & MPG444LB-BLK

1. Use your hammer and carefully pound the end plugs into the ends of the support tubes.
2. Attach a load bar support tube onto the rear cross member. Center the load bar and secure with the U-bolt and tie plate underneath as pictured below.

*\*Use Black U-Bolts for  
MPG440BLK & MPG444LB-BLK*

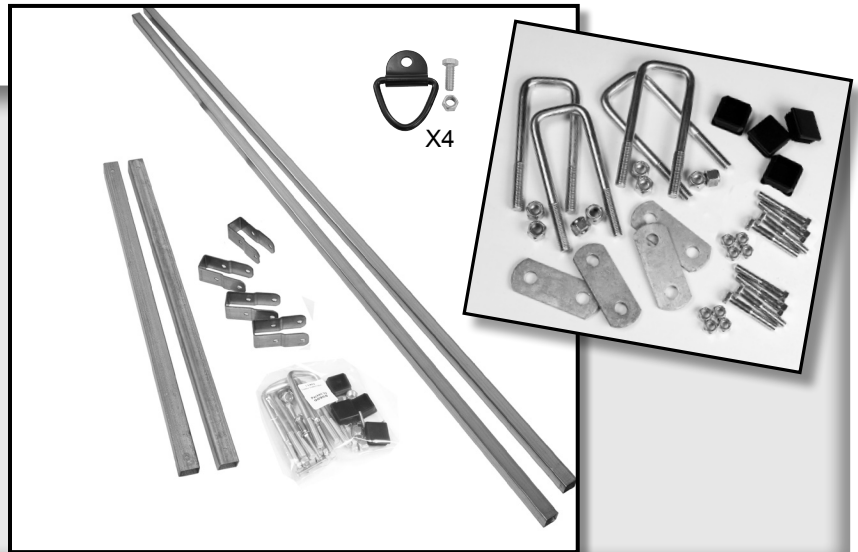

3. From the rear of the trailer, measure out 55" for placement for the front load bar support tube. Secure along the frame rails with the U-bolt and tie plate underneath.

4. Slip the load bar brackets over the new load bars (as shown) and loosely install the two small bolts / nuts through each bracket trapping the load bars inside the brackets.

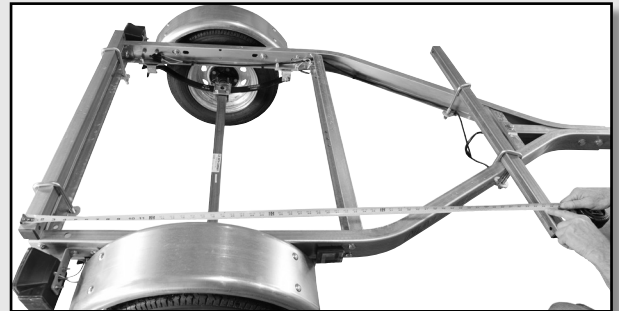

5. Install and hand tighten the bolts holding each bracket to the support tube.

6. Center the load bars to the trailer, then tighten all 8 bracket bolts.

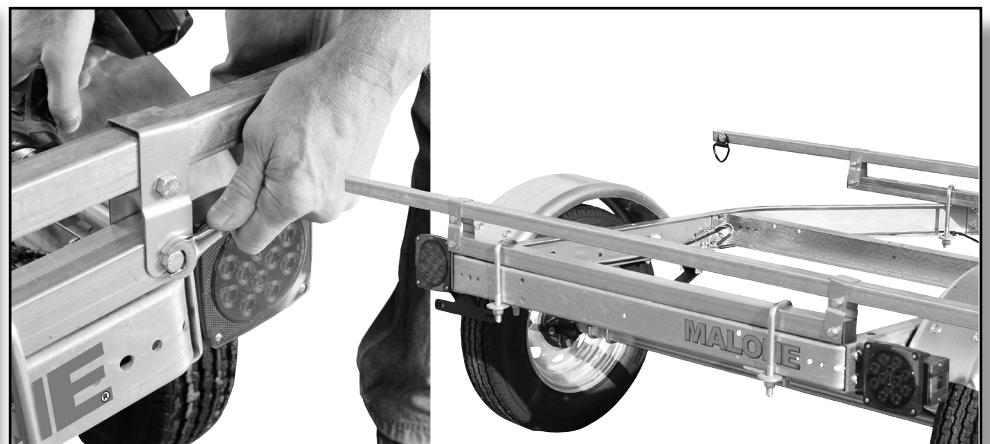
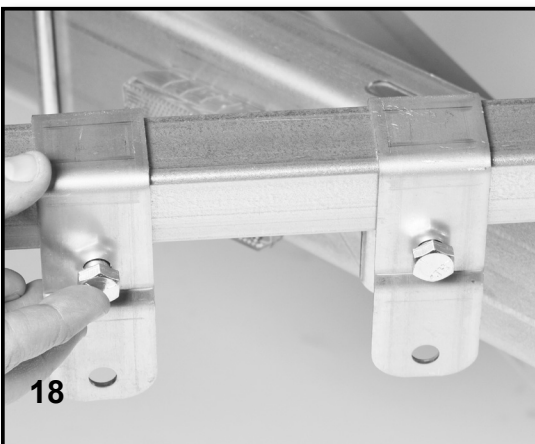

7). Install the D-Rings to the ends of the load bars. Slide a nylon lock nut into the open end of the load bar and align with the hole. Place washer under bolt head and insert it through the D-ring.

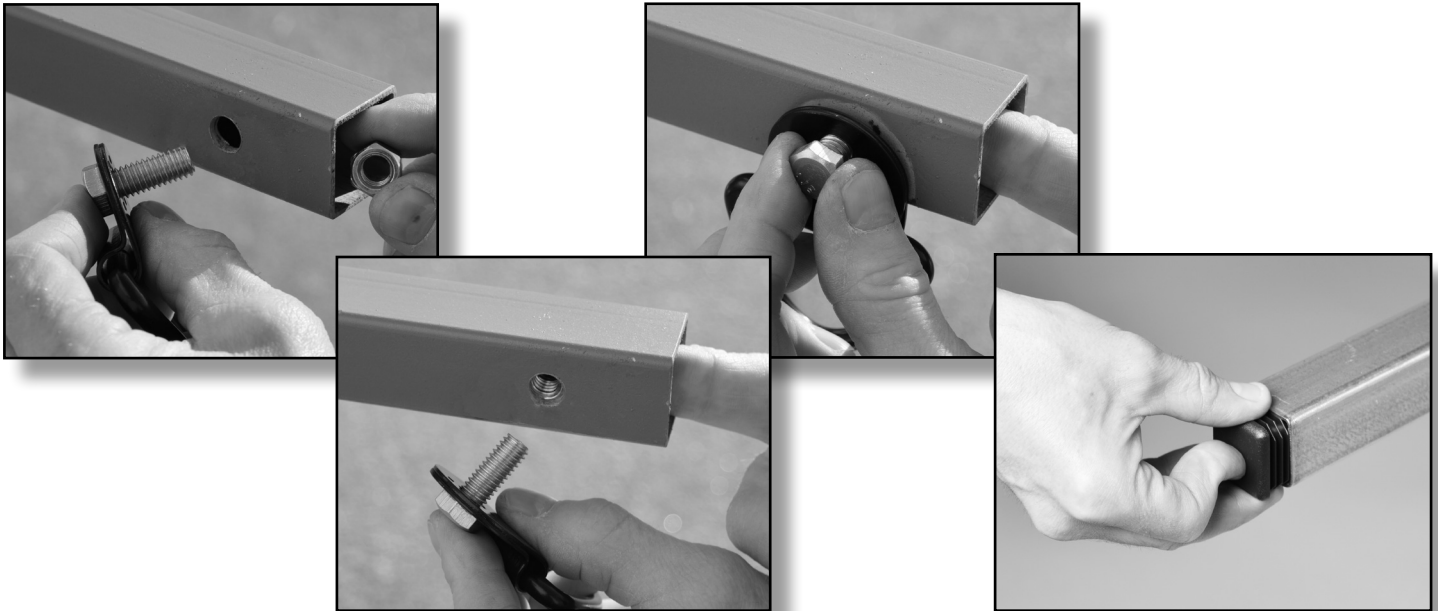

8). Align the bolt to the nut inside the cross bar and hand tighten. To secure fully, use a 9/16" wrench inside the cross bar to capture the nut inside. A 9/16" socket is used on the bolt head. Complete the cross bars with the new end caps. Repeat for remaining D-rings and end caps.

**PLEASE REFERENCE YOUR RED ENVELOPE**

**WHEN YOU RECEIVE YOUR TIRE LOADING DECAL**, please apply as shown on the drivers side of the frame or tongue. Be sure to clean the frame before applying the decal.

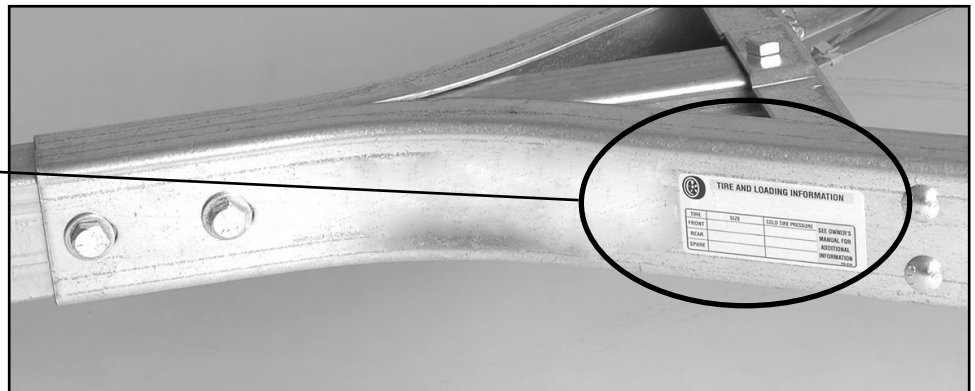

**Your MicroSport™ Trailer is now complete and ready to register and title !  
Contact your local DMV office for specific procedures in your State.**

*Visit us at [maloneautoracks.com](http://maloneautoracks.com)  
for more fine products and accessories.*

# **MALONE**<sup>®</sup>

## **CHANGING THE WAY YOU GET THERE**

### **Limited Five (5) Year Warranty**

The Malone Auto Racks (Malone) Limited 5 Year Warranty covers certain Malone-brand products that have been specifically identified for inclusion in the program. This warranty is in effect for five (5) years, from the time of sale, for the original retail purchaser of the product. This warranty is terminated after five years from the date of purchase, or, when the original retail purchaser sells or otherwise transfers the product to any other person or entity during the five year warranty period.

Subject to the limitations and exclusions described in this warranty, Malone will remedy defects in materials and/or workmanship by repairing or replacing, at its option, a defective product without charge for parts or labor. Malone may elect, at its option, not to repair or replace a defective product but rather issue to the original retail purchaser a refund equal to the purchase price paid for the product, or credit to be used toward the purchase of a replacement Malone product.

This warranty does not cover, and no warranty is given for defects or problems caused by normal wear and tear, which includes, but is not limited to, surface (aesthetic) metal corrosion, scratches, dents, deformities, accidents, unlawful vehicle operation, or any modification of a product not performed or authorized in writing by Malone.

In addition, this warranty does not cover problems resulting from conditions beyond Malone's control including, but not limited to, theft, misuse, overloading, or failure to assemble, mount or use the product in accordance with Malone's written instructions or guidelines included with the product provided to the original retail purchaser.

No warranty is given for Malone products purchased outside of the continental United States, Canada and Mexico.

If the product is believed to be defective, the original retail purchaser should contact the Malone dealer from whom it was purchased, who will give the original retail purchaser instructions on how to proceed. If the original retail purchaser is unable to contact the Malone dealer, or the dealer is not able to remedy the defect, the original retail purchaser should contact Malone by email at [support@maloneautoracks.com](mailto:support@maloneautoracks.com).

In the event that the product must be returned to Malone, a technician at the email address above will provide the original purchaser with return shipping instructions. The original purchaser will be responsible for the cost of mailing the product to Malone. In order to be eligible to receive any remedy under this warranty, a copy of the original purchase receipt, a description of the defect and a return address must be provided.

### **Disclaimer of Liability**

Repair or replacement of a defective product, or the issue of a refund or credit (as determined by Malone) is the original retail purchaser's sole and exclusive remedy under this warranty. Damage to original purchaser's vehicle, cargo, or property, and/ or to any other person or property is not covered by this warranty.

This warranty is expressly made in lieu of any and all other warranties, express or implied, including the warranties of merchantability and fitness of a particular purpose

Malone's sole liability to any purchaser is limited to the remedy set forth above. In no event will Malone be liable for any direct, indirect, consequential, incidental, special, exemplary, or punitive damages , or, for any other damages of any kind or nature (including but not limited to, lost profits, lost income or lost sales).

Some states do not allow the exclusion or limitation of incidental or consequential damages, so the above limitations may not be applicable.

In addition, all vehicular transports are potentially hazardous. Any person(s) using Malone products are personally responsible for following the given directions for use and/or installation and accepts full responsibility for any and all damages or injury of any kind including death, which may result from their use and/or installation.